

- Page 1
Section
Dimensions
Car data
- Page 2
Width
dimensions
- Page 3
Approach
Load plan
Free spaces
Function
Rails
- Page 4
Electric data
Techn. data
To be performed
by the customer
- Page 5
Description

Standard Type P210-2,0/345

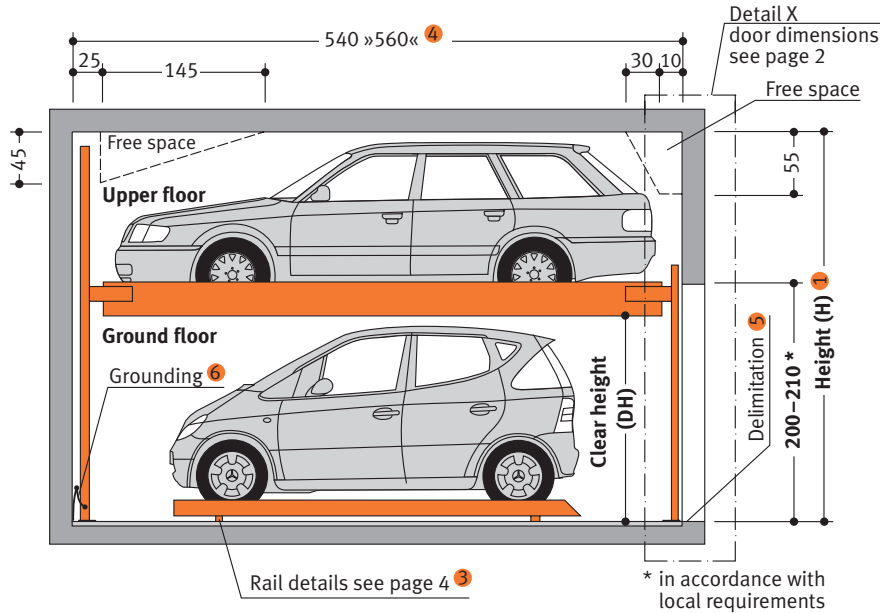

Exklusive Type P210-2,0/405

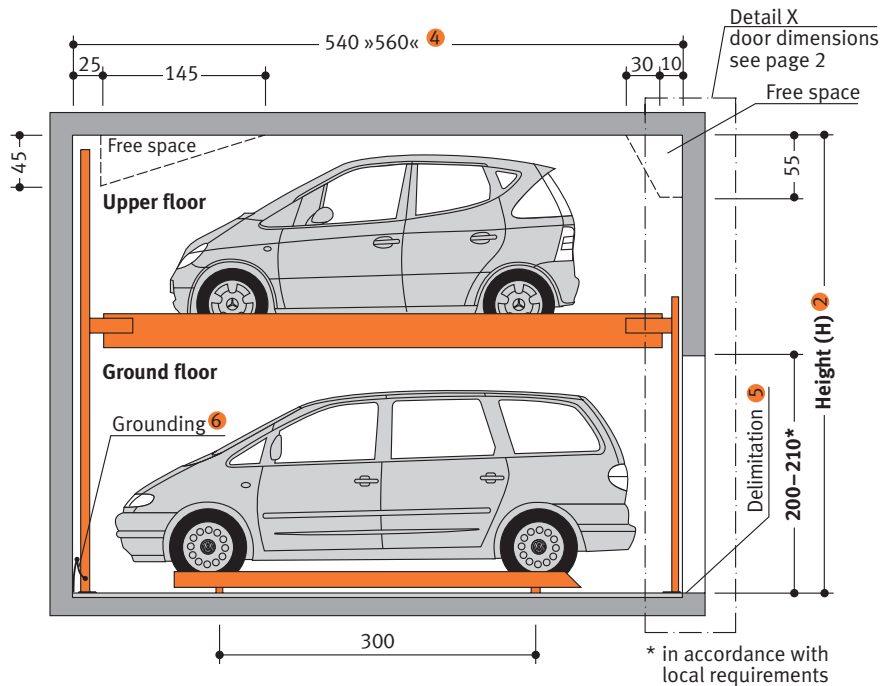

Notes

- 1 If height H is larger, higher vehicles up to 185 cm maximum can be parked in the upper floor, or there is corresponding clearance on the ceiling.
- 2 If height H is larger, higher vehicles up to 200 cm maximum can be parked in the upper floor, or there is corresponding clearance on the ceiling.
- 3 Tolerances for the evenness of the carriageway (floor) must be strictly complied with in accordance with DIN (=German Industrial Standard) No. 18202, chart 3, line 3.
- 4 Special model for cars up to a length of 5.20 m: total length 5.60 m.
- 5 On the standard version without door, a 10 cm wide yellow-black markings compliant to ISO 3864 must be applied by the customer to the edge of the platform in the access area to mark the danger zone in compliance with DIN EN 14 010 (see »Width Dimensions – Standard without Door« page 2).
- 6 Potential equalization from foundation grounding connection to system (provided by the customer).

Product Data Parking Automat P210-2,0



Number of parking spaces:
min. 3 to max. 29 vehicles

Dimensions:
All space requirements are minimum finished dimensions. Tolerances for space requirements $^{+3}_0$. Dimensions in cm.

Type	H	DH**
P210-2,0/345*	345	175
P210-2,0/405	405	210

* = standard type ** = without car

Suitable for:

Standard passenger car, station wagon/
Van. Height and length according
to contour.

Type	car height	
	upper floor	ground floor
P210-2,0/345*	150	165
P210-2,0/405	175	200

* = standard type

width	1.90 m
weight	max. 2000 kg
wheel load	max. 500 kg

Standard passenger car

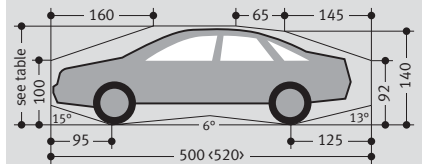

Standard station wagon/Van

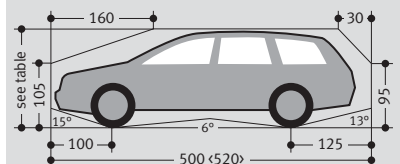

Standard passenger cars are vehicles without any sports options such as spoilers, low-profile tyres etc.



Klaus Multiparking GmbH
Hermann-Krum-Straße 2
D-88319 Aitrach
Phone +49-75 65-5 08-0
Fax +49-75 65-5 08-88
E-Mail info@multiparking.com
Internet www.multiparking.com

Page 1
Section
Dimensions
Car data

Page 2
Width
Dimensions

Page 3
Approach
Load plan
Free spaces
Function
Rails

Page 4
Electric data
Techn. data
To be performed
by the
customer

Page 5
Description

Widths – Detail X for garages with/without sliding doors

Standard model without door (lowering of the platforms: via hold-to-run-device, lifting and shifting of the platforms: automatically)

Columns per each grid unit (S = 20)

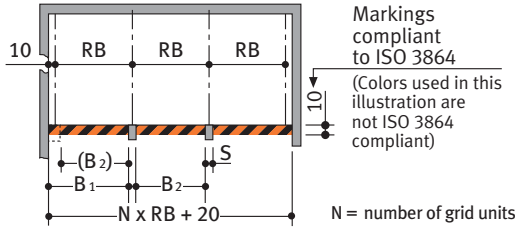

usable platform width	Grid unit width RB**	B1	B2
UF: 230 * GF: 208	250	250	230
UF: 240 GF: 208	260	260	240
UF: 250 GF: 208	270	270	250
UF: 260 GF: 208	280	280	260
UF: 270 GF: 208	290	290	270

Columns every second grid unit (S = 20)

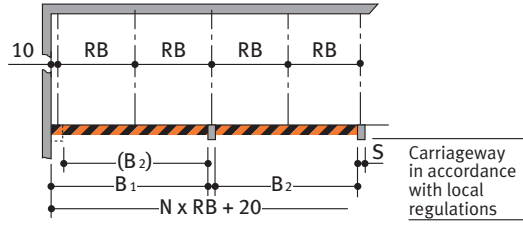

usable platform width	Grid unit width RB**	B1	B2
UF: 230 * GF: 208	250	500	480
UF: 240 GF: 208	260	520	500
UF: 250 GF: 208	270	540	520
UF: 260 GF: 208	280	560	540
UF: 270 GF: 208	290	580	560

Detail X

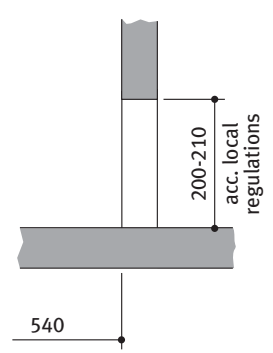

Special model (automatic control) sliding door behind columns

Columns per each grid unit (S = 20)

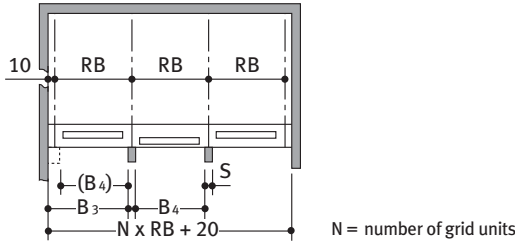

usable platform width	Grid unit width RB**	B3	B4
UF: 230 * GF: 208	250	250	230
UF: 240 GF: 208	260	260	240
UF: 250 GF: 208	270	270	250
UF: 260 GF: 208	280	280	260
UF: 270 GF: 208	290	290	270

Columns every second grid unit (S = 20)

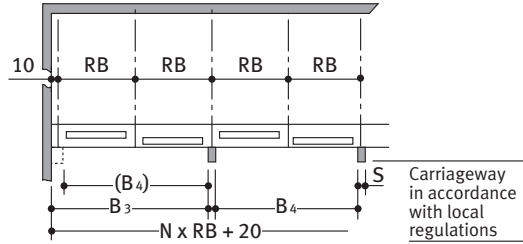

usable platform width	Grid unit width RB**	B3	B4
UF: 230 * GF: 208	250	500	480
UF: 240 GF: 208	260	520	500
UF: 250 GF: 208	270	540	520
UF: 260 GF: 208	280	560	540
UF: 270 GF: 208	290	580	560

Detail X

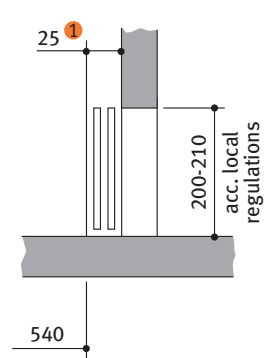

Special model (automatic control) sliding door in front of columns

Columns per each grid unit (S = 20)

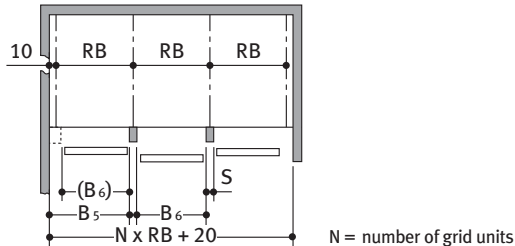

usable platform width	Grid unit width RB**	B5	B6
UF: 230 * GF: 208	250	250	230
UF: 240 GF: 208	260	260	240
UF: 250 GF: 208	270	270	250
UF: 260 GF: 208	280	280	260
UF: 270 GF: 208	290	290	270

Columns every second grid unit (S = 20)

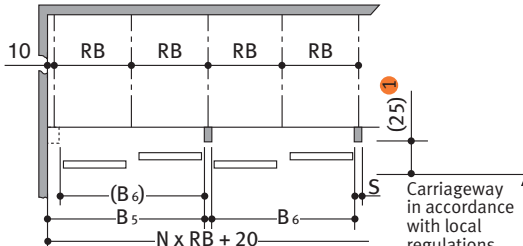

usable platform width	Grid unit width RB**	B5	B6
UF: 230 * GF: 208	250	500	480
UF: 240 GF: 208	260	520	500
UF: 250 GF: 208	270	540	520
UF: 260 GF: 208	280	560	540
UF: 270 GF: 208	290	580	560

Detail X

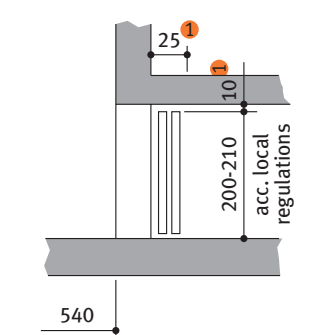

Widths – Detail X for garages with roll doors

Roll door behind columns

Columns per each grid unit

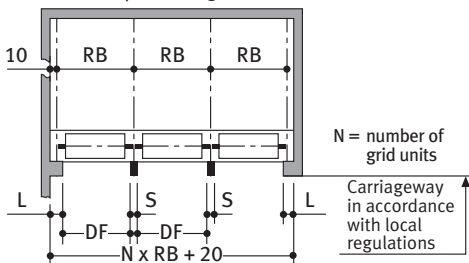

usable platform width	Grid unit width RB**	Door entrance width DF	L	S
UF: 230 * GF: 208	250	230	20	20
UF: 240 GF: 208	260	240	20	20
UF: 250 GF: 208	270	250	20	20
UF: 260 GF: 208	280	260	20	20
UF: 270 GF: 208	290	270	20	20

Detail X

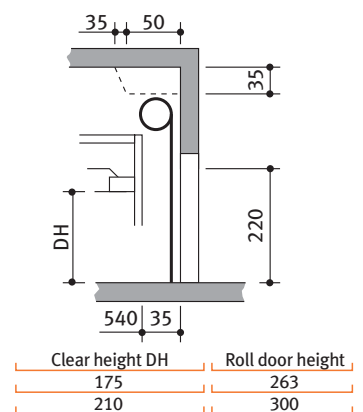

* = Standard width (parking place width on upper platforms 2.30 m).
 ** = Grid unit width **must** strictly conform to dimensions quoted!

① = Only applies to manually operated doors.
 The electrically driven doors must have the following dimensions: 10 > 20 and 25 > 35!

! End parking spaces are generally more difficult to drive into. Therefore we recommended for end parking spaces our wider platforms. Parking on standard width platforms with larger vehicles may make getting into and out of the vehicle difficult. This depends on type of vehicle, approach and above all on the individual driver's skill.

Page 1
Section
Dimensions
Car data

Page 2
Width
Dimensions

Page 3
Approach
Load plan
Free spaces
Function
Rails

Page 4
Electric data
Techn. data
To be performed
by the customer

Page 5
Description

Approach

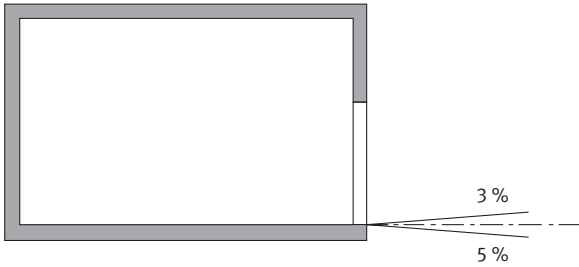

! The illustrated maximum approach angles must not be exceeded. Incorrect approach angles will cause serious manoeuvring & positioning problems on the parking system for which the local agency of Klaus accepts no responsibility.

Load plan

Forces in kN

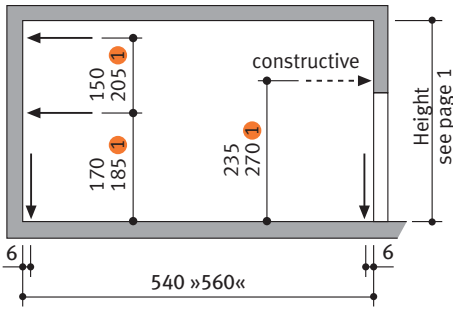

1 = Dimensions for Exclusive Type

! The system is dowelled to floor and walls. The drilling depth in the floor is approx. 15 cm. The drilling depth in the walls is approx. 12 cm. Floor and walls are to be made of concrete (grade of concrete min. C20/25)!

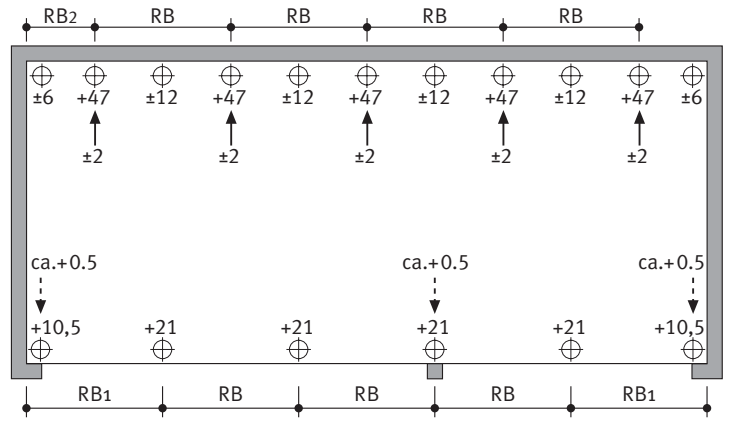

usable platform width	RB	RB1	RB2
UF: 230 *	250	260	135
UF: 240	260	270	140
UF: 250	270	280	145
UF: 260	280	290	150
UF: 270	290	300	155

Longitudinal free space; Standard parking space numbers; Denomination

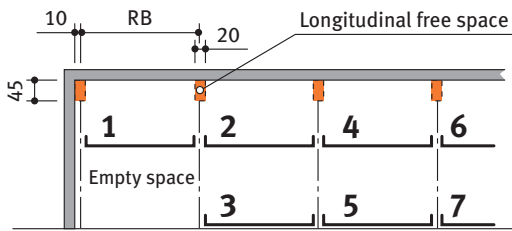

Moving direction

Upper floor

Ground floor



Descending to entrance level (standard: Hold-to-run-device)

Transverse repositioning

Function of the Parking Automat

e.g. for parking space No. 4: Check first that all doors are closed, then select No. 4 on operating panel.

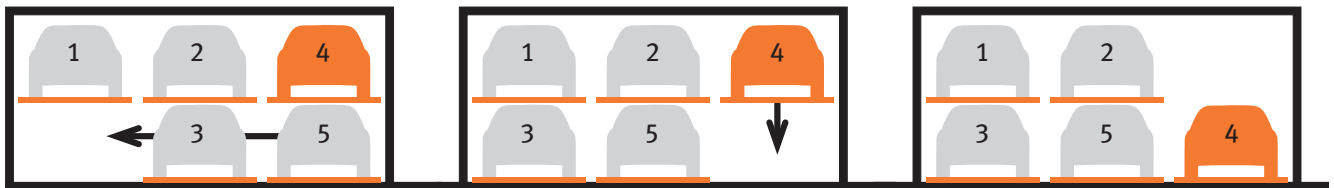

For driving the vehicle off platform No. 4 the ground floor parking platforms are shifted to the left.

The empty space is now below the vehicle which shall be driven off the platform. The platform No. 4 will be lowered.

The vehicle on platform No. 4 can now be driven off the platform.

Recesses rail system

Dependent upon the structural conditions of the garage, several different options are available for installation of the rails:

When executing the carriageway, according to raw bottom floor combined with a cement screed or
When executing the carriageway with recesses for the rails:

- The set-up of the rails amounts to 3 cm (height of floor screed 4 cm)
- After the rails have eventually been laid, the area under the rails must be topped up with concrete by the customer

Exact evenness of the carriageway:

- When exact evenness of the carriageway has successfully been accomplished, the rails may be dowelled onto it

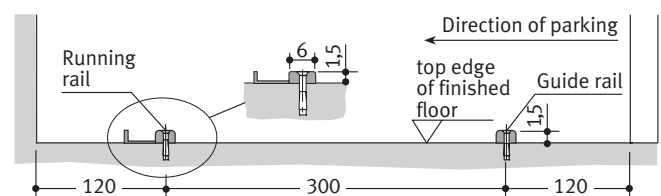
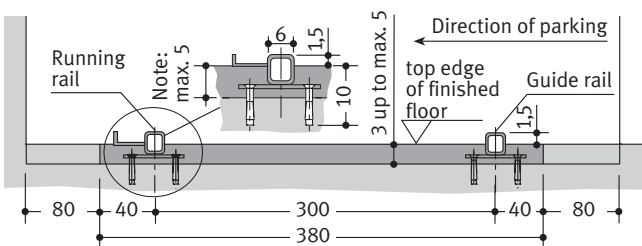

Page 1
Section
Dimensions
Car data

Page 2
Width
Dimensions

Page 3
Approach
Load plan
Free spaces
Function
Rails

Page 4
Electric data
Techn. data
To be performed
by the customer

Page 5
Description

Electrical data

Control box

The control box must be accessible at all times from outside!

Dimensions approx. 100 x 100 x 30 cm.

Cutting through of wall from control box to parking system (contact the local agency of Klaus Multiparking for clarification)

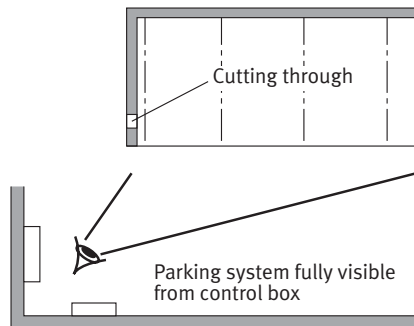

Electrical supply to the control box / Foundation earth connector

Suitable electrical supply 5 x 2.5 mm² (3 PH+N+PE) to control box with mains fuse 3 x 16 A slow or over-current cut-out 3 x 16 A trigger characteristic K or C.

Suitable electrical supply to the control box must be provided by the customer during installation. The functionality can be monitored on site by our fitters together with the electrician. If this cannot be done during installation for some reason for which the customer is responsible, the customer must commission an electrician at their own expense and risk.

In accordance with DIN EN 60204 (Safety of Machinery. Electrical Equipment), grounding of the steel structure is necessary, provided by the customer (distance between grounding max. 10 m).

Operating device

Easy-to-survey positioning (e.g. on column).

Protection against unauthorized use.

May also be recessed in wall if required.

Technical data

Range of application

Generally, this parking system is not suited for short-time parkers (temporary parkers). Please do not hesitate to contact your local KLAUS agency for further assistance.

Available documents

- wall recess plans
- maintenance offer/contract
- declaration of conformity
- test sheet on airborne and slid-borne sound

Corrosion protection

See separate sheet regarding corrosion protection.

Environmental conditions

Environmental conditions for the area of multiparking systems: Temperature range –10 to +40° C. Relative humidity 50% at a maximum outside temperature of +40° C. If lifting or lowering times are specified, they refer to an environmental temperature of +10° C and with the system set up directly next to the hydraulic unit. At lower temperatures or with longer hydraulic lines, these times increase.

Electrically driven doors

In accordance with ZH 1/494 commercially used power-driven doors must be subjected to annual inspections. We urgently recommend concluding a maintenance agreement that includes this service for the entire system.

Numbering

The standard numbering of the parking spaces is to be taken from page 3. Different numbering is only possible at extra cost. Please take note of the following specifications:

In general, the empty space must be arranged to the left. The numbers must be provided 8 – 10 weeks before the delivery date.

Sound insulation

According to DIN 4109 (Sound insulation in buildings), para. 4, annotation 4, Klaus Multiparkers are part of the building services (garage systems).

Normal sound insulation:

DIN 4109, para. 4, Sound insulation against noises from building services.

Table 4 in para. 4.1 contains the permissible sound level values emitted from building services for personal living and working areas. According to line 2 the maximum sound level in personal living and working areas must not exceed 30 dB (A).

Noises created by users are not subject to the requirements (see table 4, DIN 4109).

The following measures are to be taken to comply with this value:

- Sound protection package according to offer/order (Klaus Multiparking GmbH)
- Minimum sound insulation of building $R'_W = 57$ dB (to be provided by customer)

Increased sound insulation (special agreement):

DIN 4109, Amendment 2, Information on planning and execution, proposals for increased sound insulation.

Agreement: Maximum sound level in personal living and working areas 25 dB (A). *Noises created by users are not subject to the requirements (see table 4, DIN 4109).*

The following measures are to be taken to comply with this value:

- Sound protection package according to offer/order (Klaus Multiparking GmbH)
- Minimum sound insulation of building $R'_W = 62$ dB (to be provided by customer)

Note: User noises are noises created by individual users in our Multiparking systems. These can be noises from accessing the platforms, slamming of vehicle doors, motor and brake noises.

To be performed by the customer

Safety fences

Any constraints that may be necessary according to DIN EN 294 in order to provide protection, for pathways directly in front, next to or behind the unit. This is also valid during construction.

Numbering of parking spaces

Consecutive numbering of parking spaces.

Building services

Lighting, ventilation, fire extinguishing and fire alarm systems.

Marking

According to DIN EN 14 010, a warning that identifies this danger area must be placed in the entrance area that conforms to ISO 3864. This must be done according to EN 92/58/EWG for systems without a pit 10 cm from the edge of the platform.

Wall cuttings

Any necessary wall cuttings.

Door shields

Door shields that may be necessary. If desired, they can be ordered from Klaus Multiparking for an additional charge.

Electrical supply to the control box / Foundation earth connector

Suitable electrical supply to the control box must be provided by the customer during installation. The functionality can be monitored on site by our fitters together with the electrician. If this cannot be done during installation for some reason for which the customer is responsible, the customer must commission an electrician at their own expense and risk.

In accordance with DIN EN 60204 (Safety of Machinery. Electrical Equipment), grounding of the steel structure is necessary, provided by the customer (distance between grounding max. 10 m).

Rails

A bed should be installed and concrete should be poured around the rails installed by the manufacturer throughout their entire length.

Tolerances

The tolerances for levelness of the driving surface must conform to DIN 18202, tab. 3, line 3.

If the following are not included in the quotation, they will also have to be provided / paid for by the customer:

- Costs for final technical approval by an authorized body

Page 1
Section
Dimensions
Car data

Page 2
Width
Dimensions

Page 3
Approach
Load plan
Free spaces
Function
Rails

Page 4
Electric data
Techn. data
To be performed
by the
customer

Page 5
Description

Description

General description

Multiparking system providing independent parking spaces for cars, one on top of the other and side by side.

Dimensions are in accordance with the underlying dimensions of height and width.

The parking bays are accessed horizontally (installation deviation $\pm 1\%$).

Along the complete width of the parking automat an approach lane (driving lane in accordance with local regulations) must be available.

Parking spaces are arranged on two different levels, one level on top of the other.

The platforms of the upper floor (UF) are moved vertically, the platforms on the ground floor (GF) horizontally. At approach level (GF) there is always one parking space less available. This vacant space is used for shifting the ground floor (GF) parking spaces sideways, thus enabling the upper platform (UF) parking space located above to be lowered to approach/ground level. Consequently, a unit of three parking spaces (1 on the ground floor, 2 on the upper floor) is the smallest unit available for this parking system.

The parking automat P210 allows parking of passenger cars and station wagons.

All necessary safety devices are installed. Safety devices mainly consist of chain monitoring system and locking levers for the upper platforms. Standard delivery is made without doors. The approach/entrance area to the parking automat is monitored via light barriers. If the light barrier is interrupted, the parking system stops moving instantly.

A steel framework mounted to the floor consisting of:

- Seriated supports
- Steel pillars with sliding platform supports
- Cross and longitudinal members
- running rails for the transversely movable ground floor (GF) platforms

Platforms consisting of:

- Side members
- Cross members
- Platform base sections
- 1 wheel stop (on the right per parking space)
- Screws, small parts, etc.

Lifting device for upper floor (UF) platforms:

- Hydraulic cylinder with solenoid valve
- Chain wheels
- Chains
- Limit switches
- The platforms are suspended on four points and guided along the supports using plastic sliding bearings

Drive unit of transversely movable platforms on the ground floor (GF):

- Gear motor with chain wheel
- Running and guide rollers (low-noise)
- power supply via cable mast

Hydraulic unit consisting of:

- Hydraulic power unit (low-noise, installed onto a console with a rubber-bonded-to-metal mounting)
- Hydraulic oil reservoir
- Oil filling
- Cover with integrated internal geared wheel pump
- Pump holder
- Clutch
- 3-phase-AC-motor (3.0 kW, 230/400 V, 50 Hz)
- Motor circuit breaker
- Test manometer
- Pressure relief valve
- Hydraulic hoses (which reduce noise transmission onto the hydraulic pipe)

Hold-to-run-device (standard):

- Operation on a central control panel (operating device)
- All movements are latched automatically, except for downward movement of an OG parking space, for which the start button must be continually pressed
- Electric wiring is made from the electric cabinet by the manufacturer

Automatic control system (special design):

- Central control panel (operating device) used to select the desired parking space
- Here, it is necessary that a door system is installed in the entrance area. The doors are operated manually for a series system. If desired, this can also be done using electric motors.
- Electric wiring is made from the electric cabinet by the manufacturer

Manually operating sliding doors, which are opened sideways:

Sliding doors, approx 2500 mm x 2000 mm.

Framework

- Welded framework with one vertical center bar with stop profiles.
- The recessed grip is integrated in a vertical profile.

Fill

Standard:

- Wire grating, mesh size: 12 mm
- Not suitable for outdoor installations

Alternative:

- Trapezoidal sheet metal fill, thickness: 1 mm. Profile of sheet metal is adjusted to door width
- Wood with vertical profile, Norway spruce, composite slab, thickness: 16 mm, untreated for glazing by customer. Door framework without center bar.
- Fill provided by customer, max. weight: 10 kg/m², max. thickness: 25 mm. Fill must contribute to stabilizing the framework. Door framework without center bar.

Running rails

- The running construction consists of one door with twin-pair rollers, adjustable in height
- The running rails for the doors are fixed to the either consoles, concrete lintels or a door suspension provided by the customer by using brackets
- Guiding is enabled by 2 plastic rollers on a base plate that is dowelled to the floor

Door actuation

Standard:

- Manual, i.e., the door is opened and closed by hand

Alternative:

- Electric drive via electromotor that is mounted to the turning point of the sliding doors. The drive pinion engages into a chain mounted to the door.

For safety reasons the platforms are only moved when the doors are locked. The “Door open” and “Door closed” positions are monitored via electric sensors.

Corrosion protection

Door framework:

- Shot-blasted (purity: SA 2.5), powder-coated (Epoxy / Polyester base) RAL 7040, dry film thickness approx. 60 – 80 μ

Fill (wire grating, trapezoidal plate):

- Shot-blasted (purity: SA 2.5), powder-coated (Epoxy / Polyester base) RAL 7040, dry film thickness approx. 60 – 80 μ

Grating separation, if necessary:

- Framework with wire grating, mesh size: 12 mm, shot-blasted (purity: SA 2.5), powder-coated (Epoxy / Polyester base) RAL 7040, dry film thickness approx. 60 – 80 μ

Running rails, brackets, base plate for guiding rollers:

- Electrogalvanized

Please note:

Door covers (on the sides to cover the running rails, etc.) and door suspensions are not part of the standard delivery. They can be ordered as special equipment against additional charge.

Important! Doors in outside areas (not an underground garage):

- If doors are not installed and the system can be freely accessed, this presents a danger, for example for children playing, for which we will not be held liable. If the park automat P210 is ordered without doors, the customer expressly accepts full liability without limitations and frees the supplier from all claims. In individual cases, we reserve the right to not accept the order.
- Additionally, wetness, cold, ice and snow can cause problems when driving into and out of parking spaces. The weather conditions listed previously can cause lasting damage. Therefore, we recommend closed doors (not doors with wire mesh filling).

We reserve the right to change this specification without further notice

The Klaus company reserves the right in the course of technical progress to use newer or other technologies, systems, processes, procedures or standards in the fulfillment of their obligations other than those originally offered provided the customer derives no disadvantage from their so doing.