

- Page 1  
Section  
Dimensions  
Car data
- Page 2  
Width  
dimensions
- Page 3  
Width  
dimensions  
Approach  
Free spaces
- Page 4  
Function  
Load plan
- Page 5  
Electric data  
Techn. data  
To be performed  
by the customer
- Page 6  
Description

## Standard Type 4300

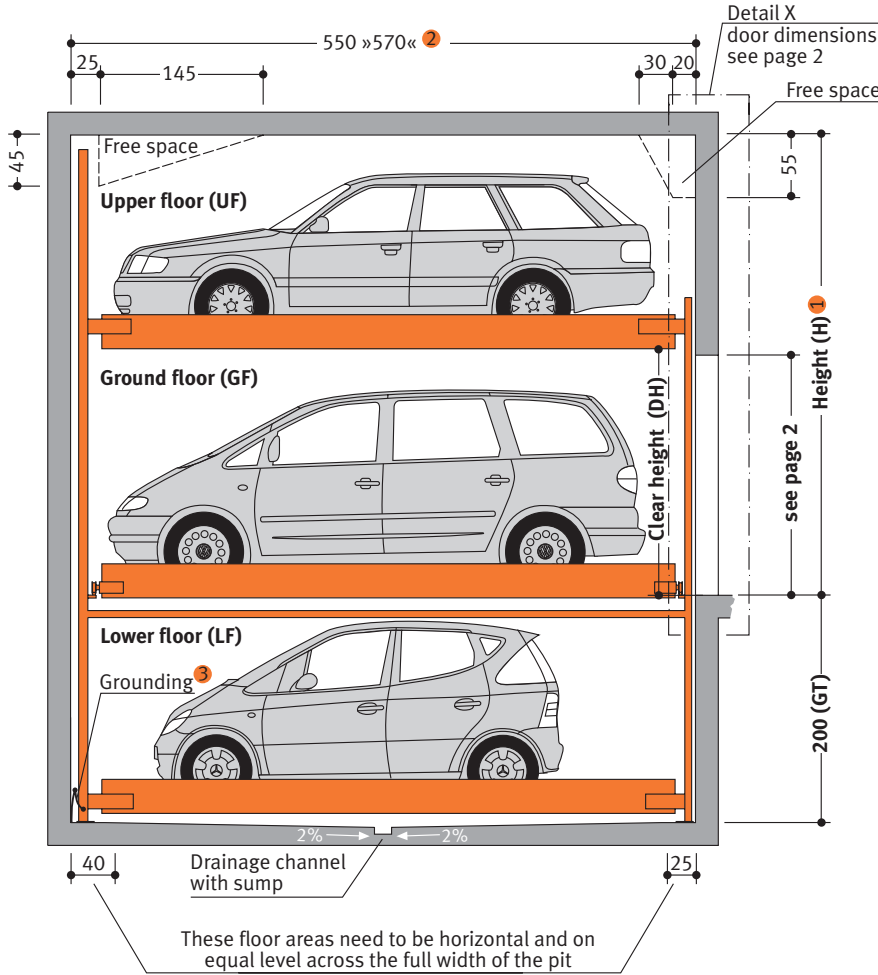

## Product Data TrendVario 4300



**Loadable up to 2,600 kg**  
Single parking spaces can also be upgraded to handle heavier loads at a later date!

**Number of parking spaces:**  
min. 5 to max. 29 vehicles

### Dimensions:

All space requirements are minimum finished dimensions. Tolerances for space requirements <sup>+3</sup>/<sub>0</sub>. Dimensions in cm.

| Type | GT  | H   | DH* |
|------|-----|-----|-----|
| 4300 | 175 | 345 | 175 |
| 4300 | 175 | 365 | 195 |
| 4300 | 175 | 380 | 210 |
| 4300 | 200 | 375 | 180 |
| 4300 | 200 | 405 | 210 |
| 4300 | 230 | 435 | 210 |

\* = without car

### Suitable for:

Standard passenger car, station wagon/  
Van. Height and length according to contour.

| Type | GT  | H   | car height |     |     |
|------|-----|-----|------------|-----|-----|
|      |     |     | UF         | GF  | LF  |
| 4300 | 175 | 345 | 150        | 170 | 150 |
| 4300 | 175 | 365 | 150        | 190 | 150 |
| 4300 | 175 | 380 | 150        | 205 | 150 |
| 4300 | 200 | 375 | 175        | 175 | 175 |
| 4300 | 200 | 405 | 175        | 205 | 175 |
| 4300 | 230 | 435 | 205        | 205 | 205 |

|                            |                   |
|----------------------------|-------------------|
| <b>width</b>               | 190 cm            |
| <b>weight</b> <sup>4</sup> | max. 2000/2600 kg |
| <b>wheel load</b>          | max. 500/650 kg   |

### Standard passenger car

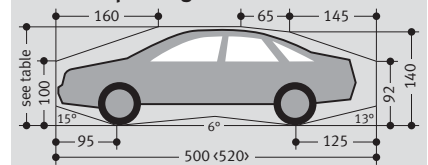

### Standard station wagon/Van/SUV\*\*

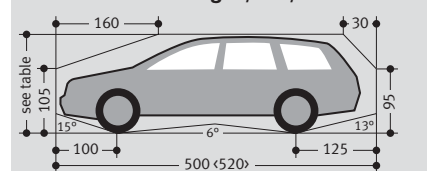

Standard passenger cars are vehicles without any sports options such as spoilers, low-profile tyres etc.

\*\* = Make sure to observe the weights and dimensions!

## Compact Type 4300

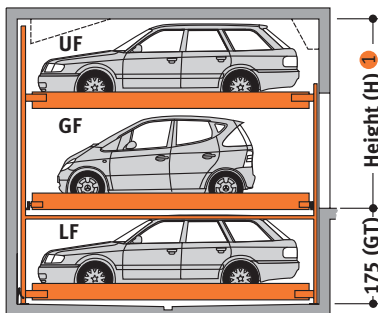

## Exclusive Type 4300

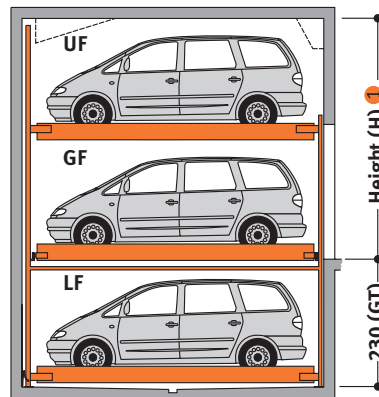

### Notes

- 1 If height H is larger, vehicles with the maximum height as applicable for the GF can be parked on the UF, otherwise there will be free space available on the ceiling.
- 2 Special model for cars up to a length of 5.20 m: total length 5.70 m.
- 3 Potential equalization from foundation grounding connection to system (provided by the customer).
- 4 Maximum load of 2,600 kg for extra charge.



**Klaus Multiparking GmbH**  
Hermann-Krum-Straße 2  
D-88319 Aitrach  
Phone +49-75 65-5 08-0  
Fax +49-75 65-5 08-88  
E-Mail [info@multiparking.com](mailto:info@multiparking.com)  
Internet [www.multiparking.com](http://www.multiparking.com)

- Page 1  
Section  
Dimensions  
Car data
- Page 2  
Width  
dimensions
- Page 3  
Width  
dimensions  
Approach  
Free spaces
- Page 4  
Function  
Load plan
- Page 5  
Electric data  
Techn. data  
To be performed  
by the customer
- Page 6  
Description

## Widths – Detail X for garages with sliding doors (Standard)

### Sliding door behind columns

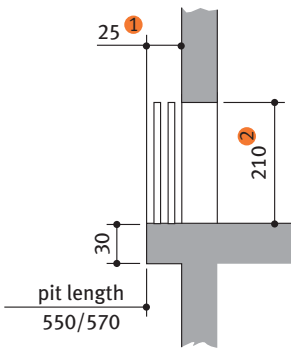

### Sliding door between columns

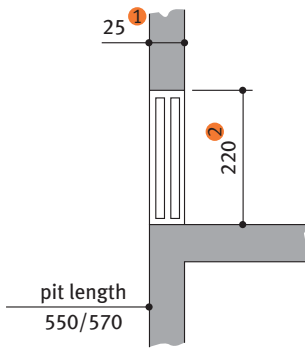

### Sliding door in front of columns

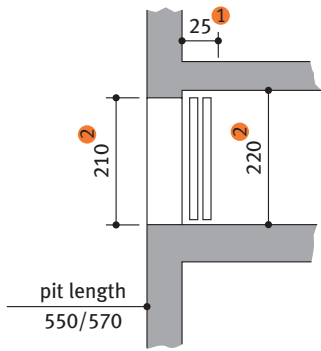

### Columns per each grid unit

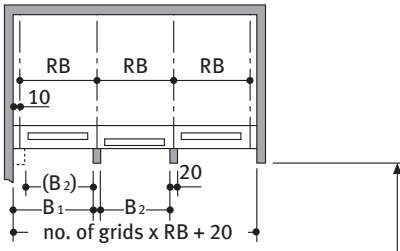

Carriageway in accordance with local regulations

| usable platform width | grid unit width RB** | B <sub>1</sub> | B <sub>2</sub> |
|-----------------------|----------------------|----------------|----------------|
| 230*                  | 250                  | 250            | 230            |
| 240                   | 260                  | 260            | 240            |
| 250                   | 270                  | 270            | 250            |
| 260                   | 280                  | 280            | 260            |
| 270                   | 290                  | 290            | 270            |

### Columns per each grid unit

Not available!

### Columns per each grid unit

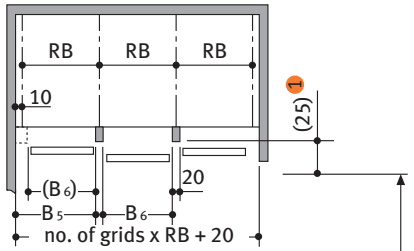

Carriageway in accordance with local regulations

| usable platform width | grid unit width RB** | B <sub>5</sub> | B <sub>6</sub> |
|-----------------------|----------------------|----------------|----------------|
| 230*                  | 250                  | 250            | 230            |
| 240                   | 260                  | 260            | 240            |
| 250                   | 270                  | 270            | 250            |
| 260                   | 280                  | 280            | 260            |
| 270                   | 290                  | 290            | 270            |

### Columns every second grid unit

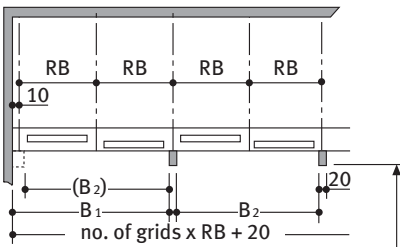

Carriageway in accordance with local regulations

| usable platform width | grid unit width RB** | B <sub>1</sub> | B <sub>2</sub> |
|-----------------------|----------------------|----------------|----------------|
| 230*                  | 250                  | 500            | 480            |
| 240                   | 260                  | 520            | 500            |
| 250                   | 270                  | 540            | 520            |
| 260                   | 280                  | 560            | 540            |
| 270                   | 290                  | 580            | 560            |

### Columns every second grid unit

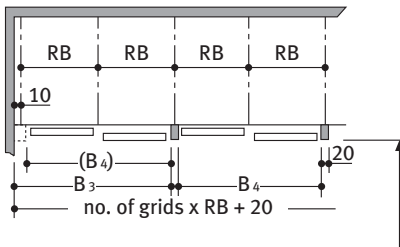

Carriageway in accordance with local regulations

| usable platform width | grid unit width RB** | B <sub>3</sub> | B <sub>4</sub> |
|-----------------------|----------------------|----------------|----------------|
| 230*                  | 250                  | 500            | 480            |
| 240                   | 260                  | 520            | 500            |
| 250                   | 270                  | 540            | 520            |
| 260                   | 280                  | 560            | 540            |
| 270                   | 290                  | 580            | 560            |

### Columns every second grid unit

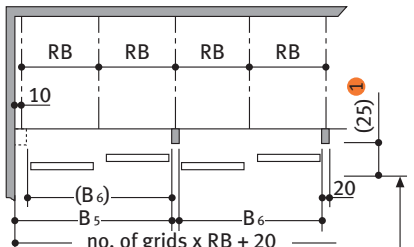

Carriageway in accordance with local regulations

| usable platform width | grid unit width RB** | B <sub>5</sub> | B <sub>6</sub> |
|-----------------------|----------------------|----------------|----------------|
| 230*                  | 250                  | 500            | 480            |
| 240                   | 260                  | 520            | 500            |
| 250                   | 270                  | 540            | 520            |
| 260                   | 280                  | 560            | 540            |
| 270                   | 290                  | 580            | 560            |

- 1 = Only applies to manually operated doors. The electrically driven doors must have 35 cm.
- 2 = For DH = 210 (see page 1) more than 10 cm are required!

\* = Standard width (parking space width 230 cm)

\*\* = Grid unit width **must** strictly conform to dimensions quoted

**!** End parking spaces are generally more difficult to drive into. Therefore we recommended for end parking spaces our wider platforms. Parking on standard width platforms with larger vehicles may make getting into and out of the vehicle difficult. This depends on type of vehicle, approach and above all on the individual driver's skill.

- Page 1  
Section  
Dimensions  
Car data
- Page 2  
Width  
dimensions
- Page 3  
Width  
dimensions  
Approach  
Free spaces
- Page 4  
Function  
Load plan
- Page 5  
Electric data  
Techn. data  
To be performed  
by the  
customer
- Page 6  
Description

## Widths – Detail X for garages with roll doors

### Roll door behind columns

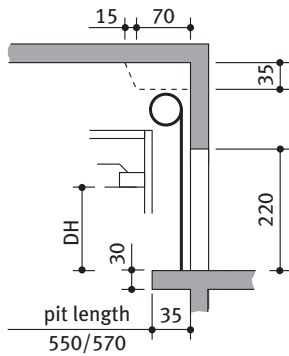

| clear height<br>DH | roll door<br>height |
|--------------------|---------------------|
| 175                | 263                 |
| 210                | 300                 |

### Columns per each grid unit

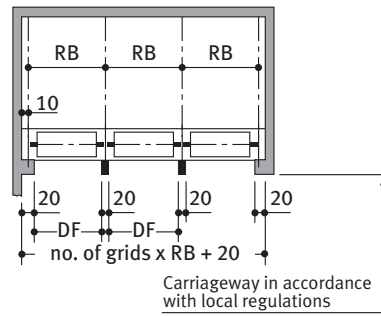

| usable platform width | grid unit width RB** | door entrance width DF |
|-----------------------|----------------------|------------------------|
| 230 *                 | 250                  | 230                    |
| 240                   | 260                  | 240                    |
| 250                   | 270                  | 250                    |
| 260                   | 280                  | 260                    |
| 270                   | 290                  | 270                    |

\* = Standard width (parking space width 230 cm)

\*\* = Grid unit width **must** strictly conform to dimensions quoted

**!** End parking spaces are generally more difficult to drive into. Therefore we recommended for end parking spaces our wider platforms. Parking on standard width platforms with larger vehicles may make getting into and out of the vehicle difficult. This depends on type of vehicle, approach and above all on the individual driver's skill.

## Approach

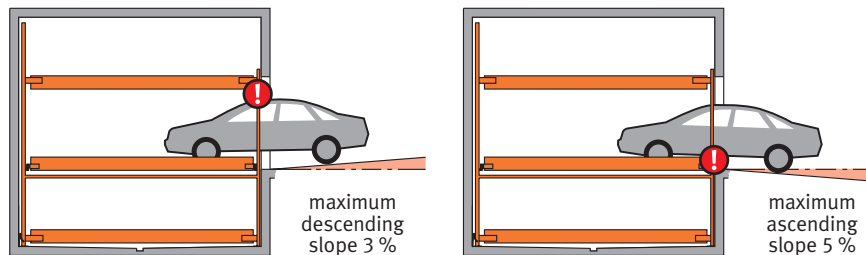

**!** The illustrated maximum approach angles must not be exceeded. Incorrect approach angles will cause serious manoeuvring & positioning problems on the parking system for which the local agency of Klaus accepts no responsibility.

## Longitudinal free space; Standard parking space numbers; Denomination

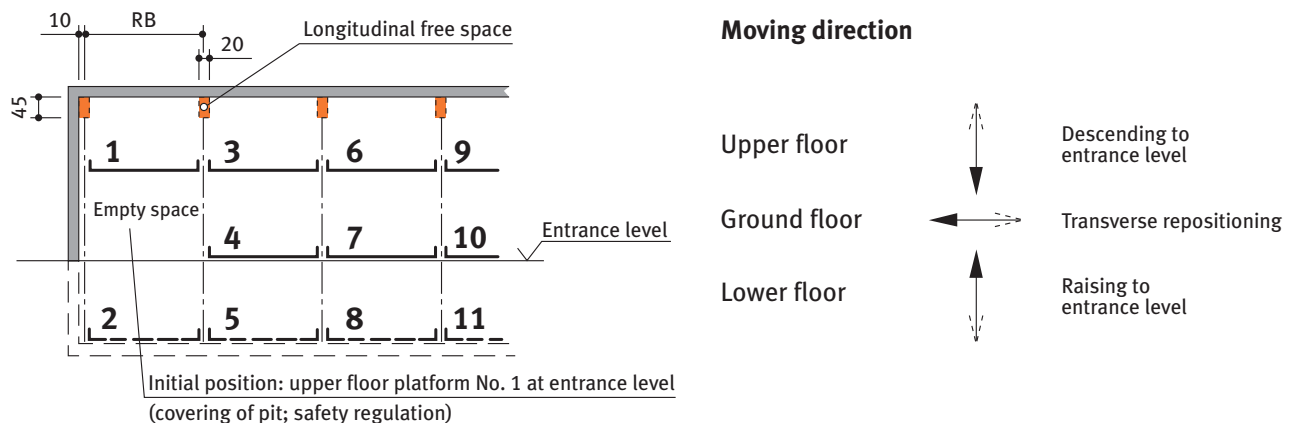

Page 1  
Section  
Dimensions  
Car data

Page 2  
Width  
Dimensions

Page 3  
Width  
Dimensions  
Approach  
Free spaces

Page 4  
Function  
Load plan

Page 5  
Electric data  
Techn. data  
To be performed  
by the customer

Page 6  
Description

## Function

e.g. for parking space No. 8:  
Check first that all doors are closed, then select No. 8 on operating panel.

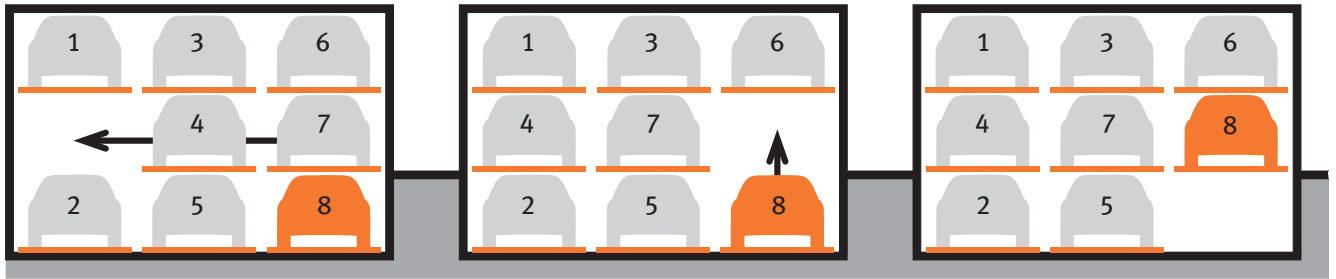

For driving the vehicle off platform No. 8 the ground floor parking platforms are shifted to the left.

The empty space is now below the vehicle which shall be driven off the platform. The platform No. 8 will be lowered.

The vehicle on platform No. 8 can now be driven off the platform.

## Load plan

### Compact Type

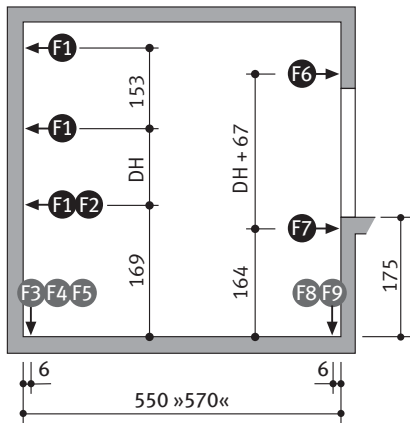

DH: see page 1

### Standard Type

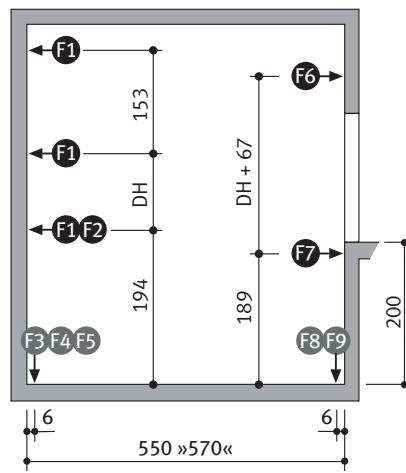

DH: see page 1

### Exclusive Type

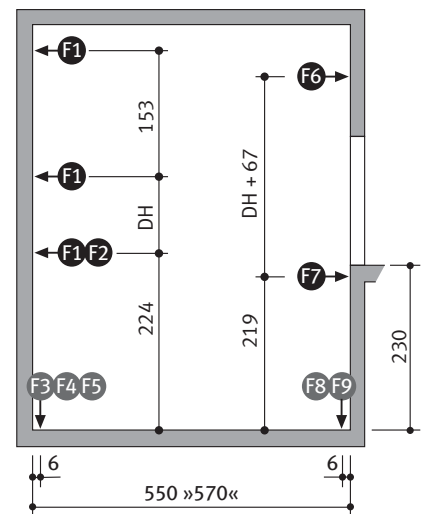

DH: see page 1

### Load plan – top view

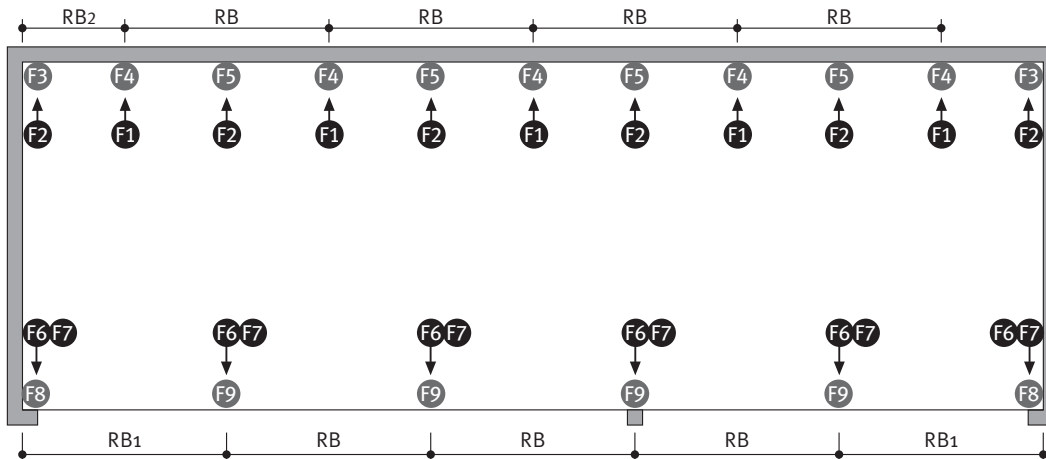

| usable platform width | RB  | RB1 | RB2 |
|-----------------------|-----|-----|-----|
| 230*                  | 250 | 260 | 135 |
| 240                   | 260 | 270 | 140 |
| 250                   | 270 | 280 | 145 |
| 260                   | 280 | 290 | 150 |
| 270                   | 290 | 300 | 155 |

| platform load | F1 | F2   | F3    | F4  | F5  | F6   | F7   | F8  | F9  |
|---------------|----|------|-------|-----|-----|------|------|-----|-----|
| 2000 kg       | ±5 | ±2,5 | ±14,5 | +70 | ±29 | ±0,2 | ±2,5 | +25 | +50 |
| 2600 kg       | ±5 | ±2,5 | ±14,5 | +80 | ±29 | ±0,2 | ±2,5 | +35 | +70 |

Forces in kN

**!** The system is dowelled to floor and walls. The drilling depth in the floor is approx. 15 cm. The drilling depth in the walls is approx. 12 cm. Floor and walls are to be made of concrete (grade of concrete min. C20/25)!

Page 1  
Section  
Dimensions  
Car data

Page 2  
Width  
Dimensions

Page 3  
Width  
Dimensions  
Approach  
Free spaces

Page 4  
Function  
Load plan

Page 5  
Electric data  
Techn. data  
To be performed  
by the customer

Page 6  
Description

## Electrical data

### Control box

The control box must be accessible at all times from outside!

Dimensions approx. 100 x 100 x 30 cm.

Cutting through of wall from control box to parking system (contact the local agency of Klaus Multiparking for clarification)

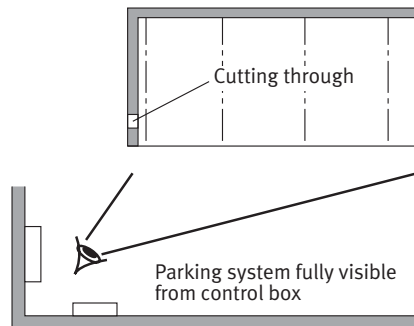

### Electrical supply to the control box / Foundation earth connector

Suitable electrical supply 5 x 2.5 mm<sup>2</sup> (3 PH+N+PE) to control box with mains fuse 3 x 16 A slow or over-current cut-out 3 x 16 A trigger characteristic K or C.

Suitable electrical supply to the control box must be provided by the customer during installation. The functionality can be monitored on site by our fitters together with the electrician. If this cannot be done during installation for some reason for which the customer is responsible, the customer must commission an electrician at their own expense and risk.

In accordance with DIN EN 60204 (Safety of Machinery. Electrical Equipment), grounding of the steel structure is necessary, provided by the customer (distance between grounding max. 10 m).

### Operating device

Easy-to-survey positioning (e.g. on column).

Protection against unauthorized use.

May also be recessed in wall if required.

## Technical data

### Range of application

Generally, this parking system is not suited for short-time parkers (temporary parkers). Please do not hesitate to contact your local KLAUS agency for further assistance.

### Available documents

- wall recess plans
- maintenance offer/contract
- declaration of conformity
- test sheet on airborne and slid-borne sound

### Corrosion protection

See separate sheet regarding corrosion protection.

### Environmental conditions

Environmental conditions for the area of multiparking systems: Temperature range –10 to +40° C. Relative humidity 50 % at a maximum outside temperature of +40° C.

If lifting or lowering times are specified, they refer to an environmental temperature of +10° C and with the system set up directly next to the hydraulic unit. At lower temperatures or with longer hydraulic lines, these times increase.

### Electrically driven doors

In accordance with ZH 1/494 commercially used power-driven doors must be subjected to annual inspections. We urgently recommend concluding a maintenance agreement that includes this service for the entire system.

### Numbering

The standard numbering of the parking spaces is to be taken from page 3. Different numbering is only possible at extra cost. Please take note of the following specifications:

In general, the empty space must be arranged to the left. The numbers must be provided 8 – 10 weeks before the delivery date.

### Sound insulation

According to DIN 4109 (Sound insulation in buildings), para. 4, annotation 4, Klaus Multiparkers are part of the building services (garage systems).

#### Normal sound insulation:

DIN 4109, para. 4, Sound insulation against noises from building services.

Table 4 in para. 4.1 contains the permissible sound level values emitted from building services for personal living and working areas. According to line 2 the maximum sound level in personal living and working areas must not exceed 30 dB (A).

*Noises created by users are not subject to the requirements (see table 4, DIN 4109).*

The following measures are to be taken to comply with this value:

- Sound protection package according to offer/order (Klaus Multiparking GmbH)
- Minimum sound insulation of building  $R'_w = 57$  dB (to be provided by customer)

#### Increased sound insulation (special agreement):

DIN 4109, Amendment 2, Information on planning and execution, proposals for increased sound insulation.

Agreement: Maximum sound level in personal living and working areas 25 dB (A). *Noises created by users are not subject to the requirements (see table 4, DIN 4109).*

The following measures are to be taken to comply with this value:

- Sound protection package according to offer/order (Klaus Multiparking GmbH)
- Minimum sound insulation of building  $R'_w = 62$  dB (to be provided by customer)

Note: User noises are noises created by individual users in our Multiparking systems. These can be noises from accessing the platforms, slamming of vehicle doors, motor and brake noises.

## To be performed by the customer

### Safety fences

Any constraints that may be necessary according to DIN EN ISO 13857 in order to provide protection for the park pits for pathways directly in front, next to or behind the unit. This is also valid during construction.

### Numbering of parking spaces

Consecutive numbering of parking spaces.

### Building services

Lighting, ventilation, fire extinguishing and fire alarm systems.

### Drainage

For the middle area of the pit we recommend a drainage channel, which you connect to a floor drain system or sump (50 x 50 x 20 cm). The drainage channel may be inclined to the side, however not the pit floor itself (longitudinal incline is available). For reasons of environmental protection we recommend to paint the pit floor, and to provide oil and petrol separators in the connections to the public sewage network.

### Wall cuttings

Any necessary wall cuttings.

### Strip footings

If due to structural conditions strip footings must be effected, the customer shall provide an accessible platform reaching to the top of the said strip footings to enable and facilitate themounting work.

### Electrical supply to the control box / Foundation earth connector

Suitable electrical supply to the control box must be provided by the customer during installation. The functionality can be monitored on site by our fitters together with the electrician. If this cannot be done during installation for some reason for which the customer is responsible, the customer must commission an electrician at their own expense and risk.

In accordance with DIN EN 60204 (Safety of Machinery. Electrical Equipment), grounding of the steel structure is necessary, provided by the customer (distance between grounding max. 10 m).

### Door shields

Door shields that may be necessary. If desired, they can be ordered from Klaus Multiparking for an additional charge.

### If the following are not included in the quotation, they will also have to be provided / paid for by the customer:

- Costs for final technical approval by an authorized body

|  |
|--|
| Page 1<br>Section<br>Dimensions<br>Car data                                  |
| Page 2<br>Width<br>Dimensions  |
| Page 3<br>Width<br>Dimensions<br>Approach<br>Free spaces                     |
| Page 4<br>Function<br>Load plan  |
| Page 5<br>Electric data<br>Techn. data<br>To be performed<br>by the customer |
| Page 6<br>Description  |

## Description

### General description

Multiparking system providing independent parking spaces for cars, one on top of the other and side by side.

Dimensions are in accordance with the underlying dimensions of parking pit, height and width

The parking bays are accessed horizontally (installation deviation  $\pm 1\%$ ).

Along the complete width of the parking automat an approach lane (driving lane in accordance with local regulations) must be available.

Parking spaces are arranged on three different levels, one level on top of the other

The platforms of both the lower floor (LF) and upper floor (UF) are moved vertically, the platforms of the ground floor (GF) horizontally. At approach level (GF) there is always one parking space less available. This vacant space is used for shifting the ground floor (GF) parking spaces sideways, thus enabling an upper floor (UF) parking space or lower floor (LF) parking space to be lowered or lifted to approach level. Consequently, a unit of five parking spaces (2 on the upper floor, 1 on the ground floor, 2 on the lower floor) is the smallest unit available for this parking system.

The TrendVario 4300 allows parking of passenger cars and station wagons.

For safety reasons the platforms can only be moved behind electromagnetically locked doors.

All necessary safety devices are installed. This consists mainly of a chain monitoring system, locking lever for the upper and lower platforms and electromagnetic door locks.

The doors can only be opened if the selected parking space has reached the park position and all openings are secured.

### A steel framework mounted inside the pit, consisting of

- Seriated supports
- Steel pillars with sliding platform supports
- Cross and longitudinal members
- running rails for the transversely movable ground floor (GF) platforms

### Platforms consisting of:

- Side members
- Cross members
- Platform base sections
- 1 wheel stop (on the right per parking space)
- Screws, small parts, etc.

### Lifting device for upper floor (UF) and lower floor (LF) platforms:

- Hydraulic cylinder with solenoid valve
- Chain wheels
- Chains
- Limit switches
- The platforms are suspended on four points and guided along the supports using plastic sliding bearings.

### Drive unit of transversely movable platforms on the ground floor (GF):

- Gear motor with chain wheel
- Chains
- Running and guide rollers (low-noise)
- power supply via cable mast

### Hydraulic unit consisting of:

- Hydraulic power unit (low-noise, installed onto a console with a rubber-bonded-to-metal mounting)
- Hydraulic oil reservoir
- Oil filling
- Cover with integrated internal geared wheel pump
- Pump holder
- Clutch
- 3-phase-AC-motor (3.0 kW, 230/400 V, 50 Hz)
- Motor circuit breaker
- Test manometer
- Pressure relief valve
- Hydraulic hoses (which reduce noise transmission onto the hydraulic pipe)

### Manually operating sliding doors, which are opened sideways:

Sliding doors, approx 2500 mm x 2000 mm.

### Framework

- Welded framework with one vertical center bar with stop profiles.
- The recessed grip is integrated in a vertical profile.

### Fill

Standard:

- Wire grating, mesh size: 12 mm
- Not suitable for outdoor installations

Alternative:

- Trapezoidal sheet metal fill, thickness: 1 mm. Profile of sheet metal is adjusted to door width
- Wood with vertical profile, Norway spruce, composite slab, thickness: 16 mm, untreated for glazing by customer. Door framework without center bar.
- Fill provided by customer, max. weight: 10 kg/m<sup>2</sup>, max. thickness: 25 mm. Fill must contribute to stabilizing the framework. Door framework without center bar.

### Running rails

- The running construction consists of one door with twin-pair rollers, adjustable in height
- The running rails for the doors are fixed to the either consoles, concrete lintels or a door suspension provided by the customer by using brackets
- Guiding is enabled by 2 plastic rollers on a base plate that is dowelled to the floor

### Door actuation

Standard:

- Manual, i.e., the door is opened and closed by hand

Alternative:

- Electric drive via electromotor that is mounted to the turning point of the sliding doors. The drive pinion engages into a chain mounted to the door.

For safety reasons the platforms are only moved when the doors are locked. The “Door open” and “Door closed” positions are monitored via electric sensors.

### Corrosion protection

Door framework:

- Shot-blasted (purity: SA 2.5), powder-coated (Epoxy / Polyester base) RAL 7040, dry film thickness approx. 60 – 80  $\mu$

Fill (wire grating, trapezoidal plate):

- Shot-blasted (purity: SA 2.5), powder-coated (Epoxy / Polyester base) RAL 7040, dry film thickness approx. 60 – 80  $\mu$

Grating separation, if necessary:

- Framework with wire grating, mesh size: 12 mm, shot-blasted (purity: SA 2.5), powder-coated (Epoxy / Polyester base) RAL 7040, dry film thickness approx. 60 – 80  $\mu$

Running rails, brackets, base plate for guiding rollers:

- Electrogalvanized

### Please note:

Door covers (on the sides to cover the running rails, etc.) and door suspensions are not part of the standard delivery. They can be ordered as special equipment against additional charge.

### Control system:

- Central control panel (operating device) used to select the desired parking space
- With series installation, the doors are opened manually. If desired, this can also be done using electric motors
- Electric wiring is made from the electric cabinet by the manufacturer

## We reserve the right to change this specification without further notice

The Klaus company reserves the right in the course of technical progress to use newer or other technologies, systems, processes, procedures or standards in the fulfillment of their obligations other than those originally offered provided the customer derives no disadvantage from their so doing.